



Seth Rhodes  
Ryan Castillo  
Houman Pousti

# STINGER AV

Fast Acquisition Real-Time Tracking Machine

# DESIGN CONCEPT

The Stinger Autonomous Vehicle is a proof of concept designed for high-risk operations. Stinger is to be utilized by trained county/state law enforcement, federal agencies, and military operations. The Stinger AV autonomously seeks out targets of interest in order to mark, locate, deter, immobilize or destroy. The Stinger AV is safely operated from a remote location through long range wireless networks.



# MOTIVATION

- Crowd Control
- Intimidation Factor
- Audible and Visual Warnings
- Threat Detection
- Up-to-date Image Processing Techniques
- Advanced Optical Sensors
- Fast Response
- Powerful processing capabilities
- Lightweight and Agile



# DESIGN EVOLUTION

Began with a robust military inspired design

- Pros: Intimidation factor  
Strong chassis  
Can be deployed in harsh environments
- Cons: Too Bulky  
Not maneuverable enough

Moved to a two wheeled design

- Pros: Agile
- Cons: Requires a balancing system  
Easily disrupted

Switched to a tank based design

- Pros: Increased intimidation factor  
Maneuverability of a two-wheeled system
- Cons: Heavier than the previous iteration





# GOALS & OBJECTIVES

- ☑ The probe vehicle will have the ability to autonomously navigate an environment that is unfamiliar to the operator
- ☑ The probe vehicle will be able to autonomously seek out different colored balloons with the use of image processing
- ☑ Robust to noise and occlusion
- ☑ Multi-terrain operability
- ☑ The operator will have a ground control station which provides a live feed from the perspective of the probe vehicle
  - \*Live feed imagery was removed to reduce latency.
- ☑ The operator will have the capability of commandeering control of the probe vehicle at any point in time in order to navigate to and from the site or in case an object of interest is apparent to the operator but not the probe vehicle
- ☑ The probe vehicle will communicate with ground control via Wi-Fi (or other RF technology) on a dedicated wireless network

# PCB DESIGN REQUIREMENTS

- Must be small enough to fit inside a typical RC car
- Board outline must be no larger than the largest component
- Transmission line impedance must be carefully controlled
- Differential Paired Traces
- Component selection must keep manufacturability in mind
- Surface Mount vs Through Hole

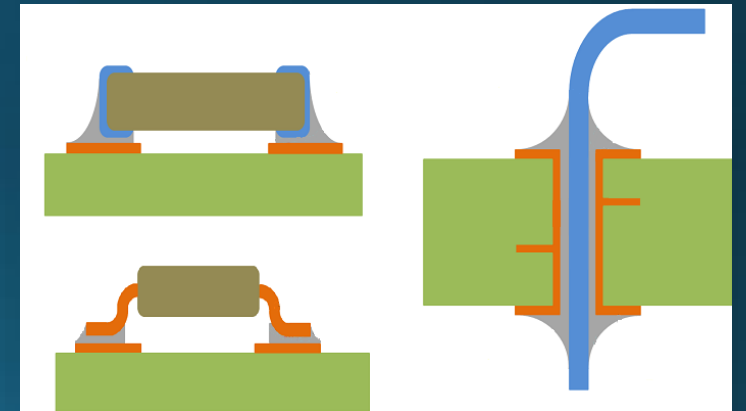

# COMPONENT DESIGN DECISIONS

# POWER SUPPLY OPTIONS

- Lithium Ion Polymer Batteries (LiPO)
- Provides 3.7V nominal/ rated for 4.2V
- Easily obtainable
- Volatile
- Usually contains Onboard Protection System (OPS\_ for additional safety measures
- Higher density than rechargeable Nickel-Metal-Hydride (Ni-MH) and Nickel-Cadmium (NiCad) cells and Lead-Acid batteries
- Lightweight



# BATTERY COMPARISON CHART

Battery Type	Volume (cubic inches)	Weight (g)	Capacity (mAh)	Voltage (V) Max/Nominal	Recharge Capable	Number of Cycles	Cost (dollars)
Alkaline (AAA)	0.24	12.00	1150	1.5/1.2	No	One time use	1-4.00 (4pk)
Alkaline (AA)	0.51	24.00	2122	1.5/1.2	No	One time use	1-4.50 (4pk)
NiMH (AA)	0.51	26.00	1000	1.5/1.2	Yes	1000	7-14 (4pk)
Lithium Polymer	0.61	20.00 (Raw)	1000	4.2/3.7	Yes	300-400	5-10 (ea)
Lithium Ion	0.61	22.68	1000	4.2/3.7	Yes	300-400	5-10 (ea)

# POWER SUPPLY

- Power Source
  - 2 ea. Replaceable/rechargeable Lipo Batteries
  - Lightweight, high power density
  - 3.7V Nominal/ ~4.2V Fully Charged
  - >30 minutes operating time
- Challenges
  - Volatile, requires monitoring system
  - Charging in series can cause potential fire hazard
  - Switching unit had to be designed to charge batteries
    - In parallel, and discharge in series.

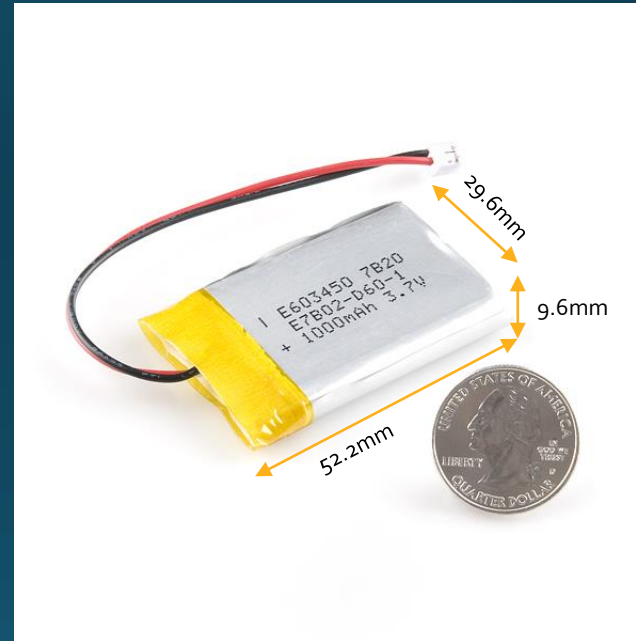

# BATTERY MANAGEMENT CONTROLLER

- Texas Instruments BQ21040
- Operates off wide range of input voltage
- OV protection supports low-cost unregulated adapters
- Programmable fast charge current through external resistor
- Charge speed up to 800mA
- 1% charge voltage accuracy
- 10% charge current accuracy

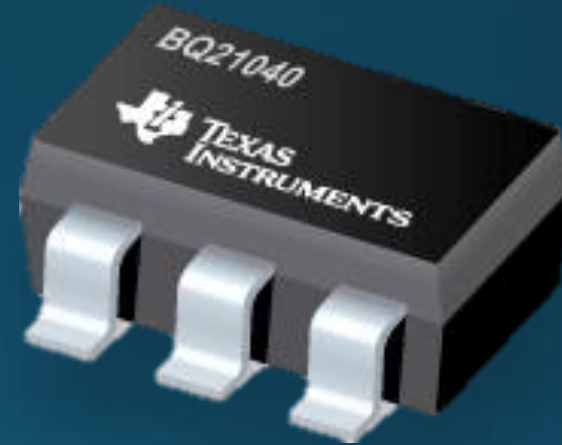

# BATTERY MANAGEMENT SYSTEM

Manufacturer	Part Number	# of cells	Cost	Unit
Microchip	MCP73831/2	Single	\$0.59	ea.
Texas Instruments	BQ21040	Single	\$0.14	ea.
NXP	MC34673	Single	\$0.44	ea.

BMC Final decision:

- ▶ The BQ21040 by Texas Instruments was chosen for our final design.
- ▶ The ICs met most all of our needs; however, The BQ21040 was priced well below its competitors and lead times for shipping made solidified the teams decision

# VOLTAGE REGULATOR

- Purpose
  - Supply constant/reliable voltage to:
    - Raspberry Pi
      - Input voltage: 4.75V – 5.25V
      - **\*\*Recommended 2.5A power supply\*\***
    - Microcontroller (ATMEGA328P)
      - Operating Voltage: 1.8 – 5.5V
      - Current draw 01.uA – 0.2mA
    - Motor Driver (L293D)
      - Operating Voltage: 4.5 – 36V
      - Output current: 600mA – 1.2A (peak)

Our design team decided on using a voltage regulator capable of producing a continuous 5V output capable of providing at least 2A for peak load demand.

**\*\*Developmental testing conducted by the team of the Raspberry Pi under computationally heavy loads showed less than 1A current draw.**

# VOLTAGE REGULATOR TYPES

- Linear Voltage Regulator
  - Pros:
    - Simple Design
    - Low Cost
  - Cons:
    - Inefficient
    - Wasteful energy in form of heat
    - May require large heat sink (increased form factor)
- Switching Voltage Regulator (Buck Converter)
  - Pros:
    - Efficient
    - Low power usage (low heat)
    - Great for battery powered devices
  - Cons:
    - More complex
    - Higher cost



# VOLTAGE REGULATOR COMPARISON

- Linear Voltage Regulator (PN: ba50dd0t)
  - Provides 5V/2A
- Switching Voltage Regulator (PN: MICC2177-5.0)
  - Provides 5V/2.5A

Our design team settled on the switching voltage regulator (MICC2177-5.0)

Rationale: The Stinger AV is battery operated and is intended to handle harsh environments of extreme heat. A switching regulator is ideal for battery powered devices and small enclosures with limited cooling/airflow. The increased cost was deemed necessary by the team in order to satisfy design specification.

# MICROCONTROLLERS

MCU	Operating Voltages	# of PWM Channels	ADC	# of I/O	Power Consumption – Active	Power Consumption – Power-down Mode	CPU Speed
ATMEGA168-20PU	1.8V – 5.5V	6	6@10-bit	23	1MHz, 1.8V, 25°C 250µA	1.8V, 25°C 0.1µA	20 MIPS
ATMEGA328P-PU	1.8V – 5.5V	6	6@10-bit	23	1MHz, 1.8V, 25°C 200µA	1.8V, 25°C 0.1µA	20 MIPS
ATTINY85-20PU	2.7V – 5.5V	2	4@10-bit	6	1MHz, 2.7V, 25°C 450µA	2.7V, 25°C 0.15µA	20 MIPS
PIC16F688	2.0V – 5.5V	0	8@10-bit	12	1MHz, 2.0V, 25°C 55µA	2.0V, 25°C 50nA	5 MIPS
MSP430G2553	1.8V – 3.6V	0	8@10-bit	16	1MHz, 2.2V, 25°C 230µA	2.2V, 25°C 0.1µA	16MIPS

# COMMUNICATION

- ▶ Microprocessor must communicate with microcontroller
- ▶ Latency must be as low as possible
- ▶ Must be scalable to accommodate additional peripherals

Standard	TX Type	# Signal Wires	Data Rate & Distance	Scalability	Application Example
<b>UART</b>	Asynchronous	2	20kbps @ 15m	Low (point-to-point)	Diagnostic display
<b>SPI</b>	Synchronous	4+	25Mbps @ 0.1m	Medium (chip selects)	High speed chip to chip link
<b>I<sup>2</sup>C</b>	Synchronous	2	1Mbps @ 0.5m	High (Identifier)	System sensor network

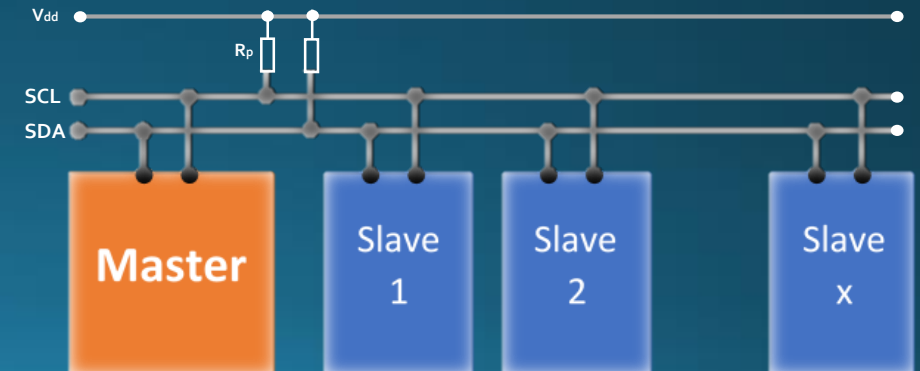
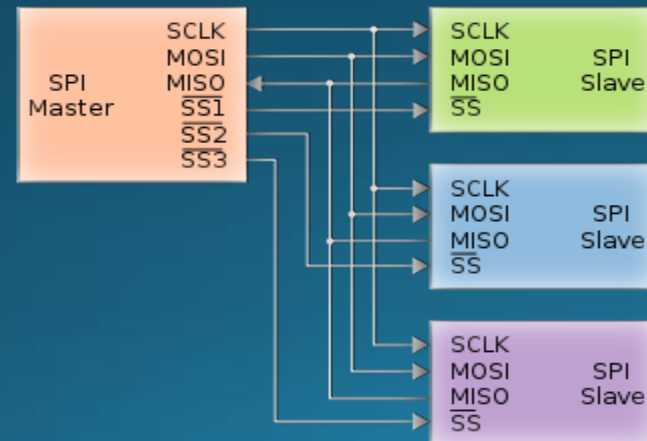
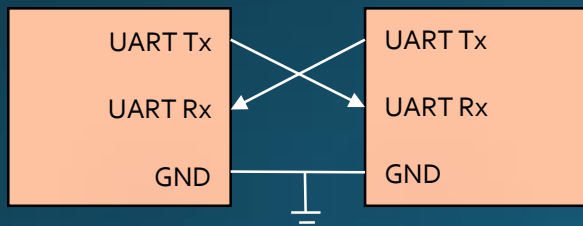

# SYSTEM BLOCK DIAGRAM

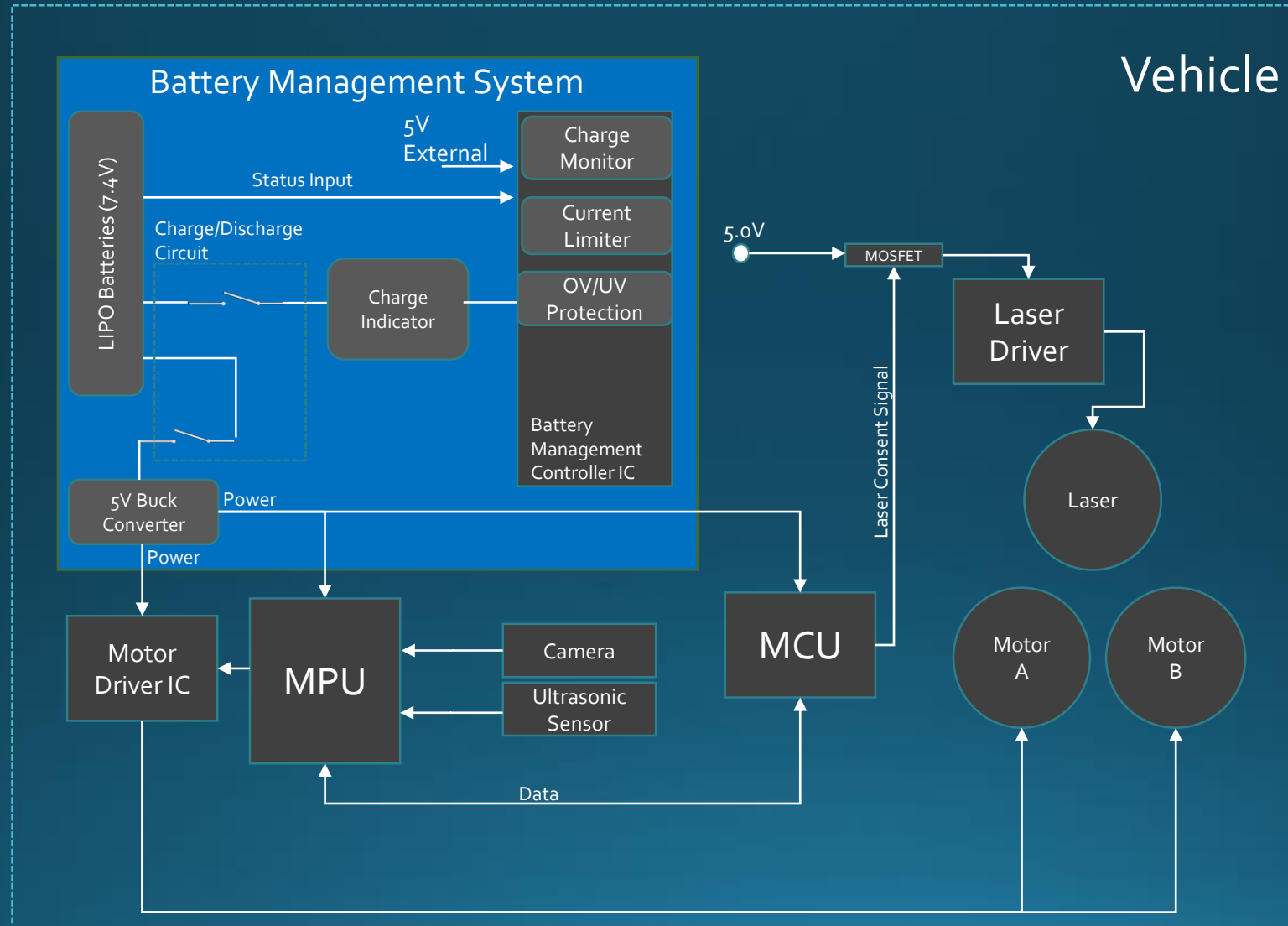

# IMAGE PROCESSING/CV

# COMPUTING MODULES SELECTION

- Used to execute the image processing algorithms
- Must be powerful enough to execute highly computational codes in a timely manner
- Factors considered when selecting the Computing Module:
  1. Dynamic Memory Space
  2. GPIO count
  3. Maximum output current
  4. Cost



# COMPUTING MODULE COMPARISON

Computer	Memory Type and Space	GPIO count	I_MAX (mA)	Cost
Raspberry Pi 3 Computer Board	1 GB of LPDDR2 RAM	45	50	\$39.95
Banana PI Pro Computer Board	1 GB of DDR3 RAM	40	50	\$47.99
RoBoard RB-100 Single Board Computer	256 MB of DDR2 RAM	200	N/A	\$250.00
RoBoard RB-110 Single Board Computer	256 MB of DDR2 RAM	200	N/A	269.99

# SOFTWARE

- Written in Python Programming language
- Opencv and Numpy libraries were both used
- PiCamera module used to acquire the imagery data
  - PiCamera module was selected because of the quality of images and the availability of the PiCamera library
- Design Objective of the software:
  1. Find the color of interest
  2. Validate the color-based-detection

# DESIGN PROCESS

1. Color Model Transformation
2. Thresholding the color and developing a binary mask
3. Applying morphological processes to the mask
4. Finding the minimum enclosing circle
5. Validating the process mask

# COLOR MODEL TRANSFORMATION



RGB  $\rightarrow$  HSV

$$\begin{aligned} M &= \max\{r, g, b\} \\ m &= \min\{r, g, b\} \\ c &= M - m \\ v &= M \\ h &= \begin{cases} \left(\frac{g-b}{c} \bmod 6\right) * 60 & r = M, c \neq 0 \\ \left(\frac{b-r}{c} + 2\right) * 60 & g = M, c \neq 0 \\ \left(\frac{r-g}{c} + 4\right) * 60 & b = m, c \neq 0 \\ 0 & c = 0 \end{cases} \\ s &= \frac{c}{v} \end{aligned}$$

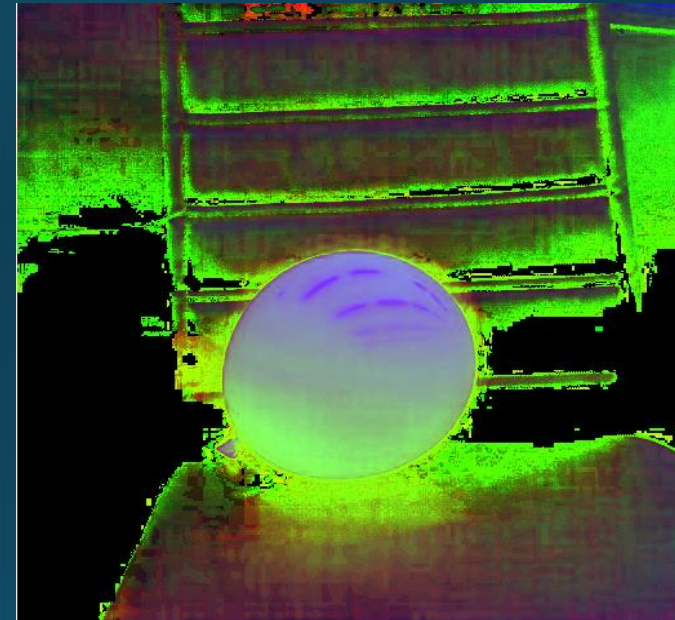

# COLOR THRESHOLDING

- We define a range for Hue that corresponds to the color of interest (Blue in this case →)
- Then we define a mask that has ones for the Pixels that have the Hue value within the range of interest and zero otherwise
- For some colors, we also limit the range of Saturation
- The developed mask based on Saturation range is logically anded with the Hue mask
- Problems with the mask shown:
  1. Noise
  2. Accuracy

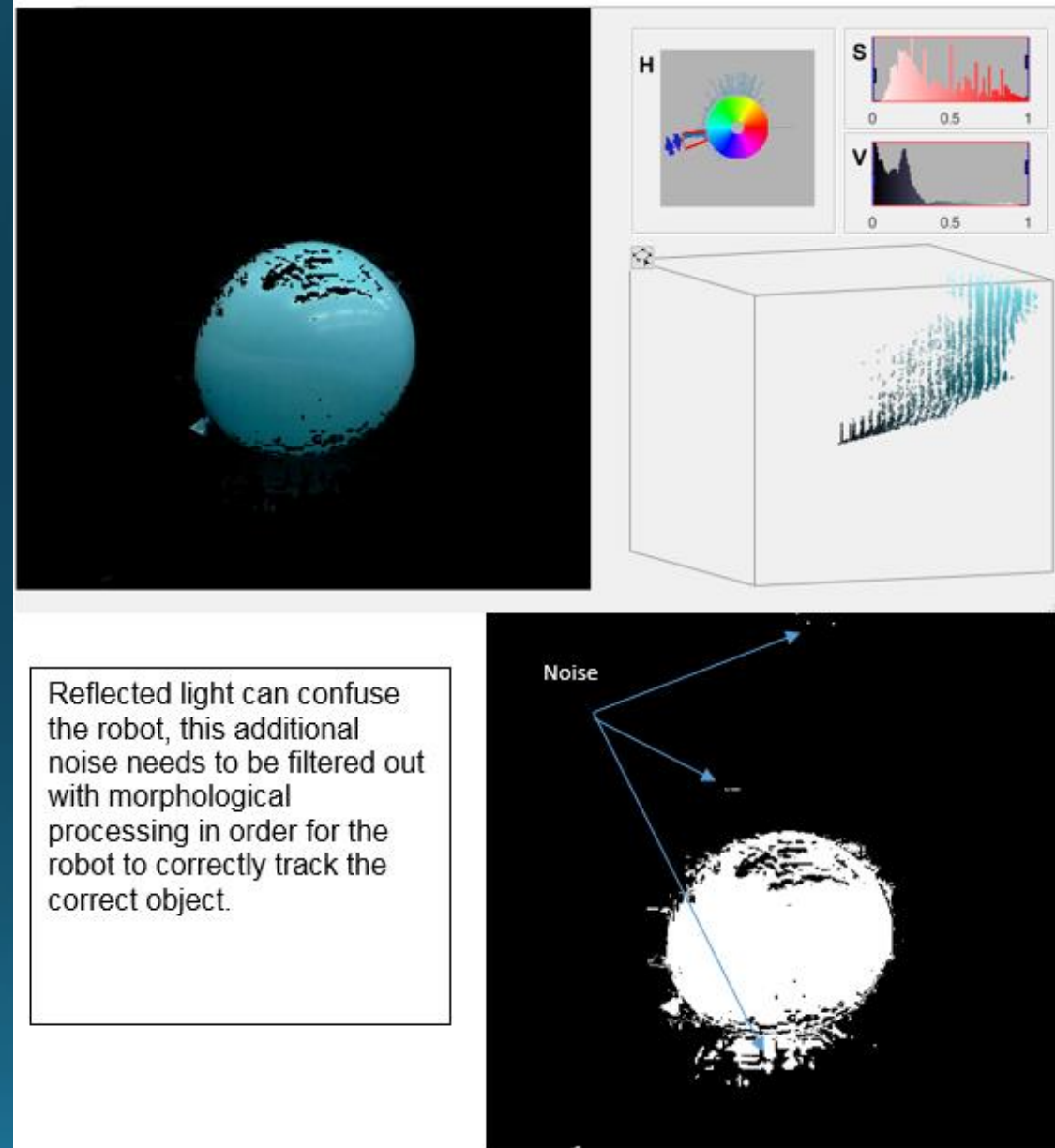

# MORPHOLOGICAL PROCESS

- Erosion:
  - Used to deteriorate the mask in a circular fashion
  - Destroys noises in binary masks (White dots)
  - Maintains the structure of the mask
  
- Dilation
  - Used to expand the mask
  - Fills up holes in solid structures
  - Maintains the structure of the mask

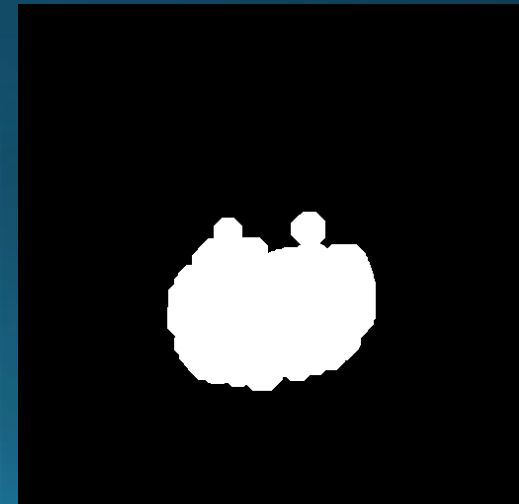
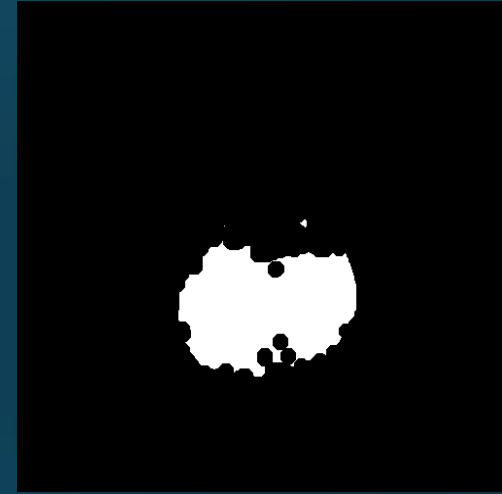



# MINIMUM ENCLOSING CIRCLE

- The Binary mask is used to develop a contour
- The contour is then used to find a minimum radius circle that encloses the contour
- The center of the circle is the location of the object in pixels

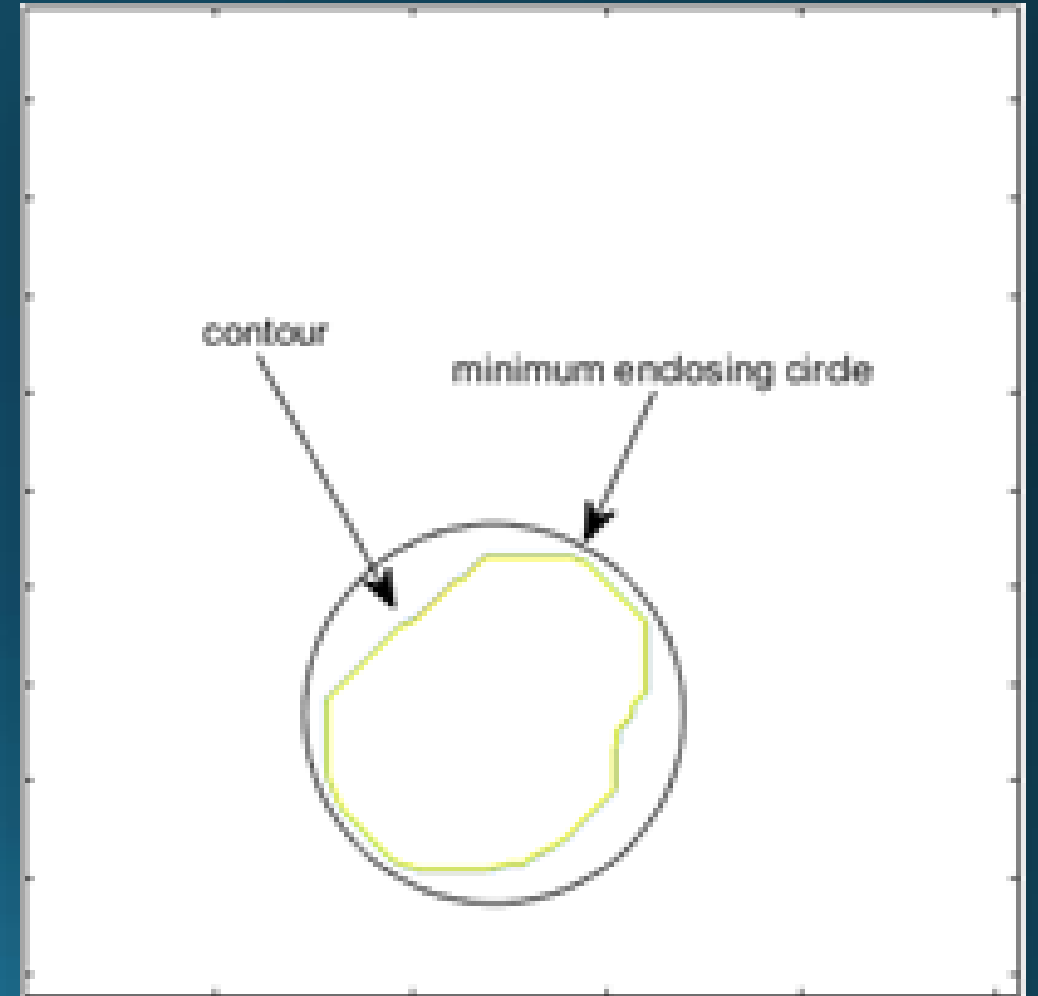

# AREA-BASED VALIDATION

$$A_d = A_{\text{assumed}} - A_{\text{mask}}$$

$$r = A_d / A_{\text{assumed}}$$

$$\text{Confidence} = 1 - r$$

Confidence  $\geq 70 \rightarrow$  Circle detected

- The purpose of this calculation is to find the ratio of the area of the contour with respect to the enclosing circle
- How do we calculate the area of the contour??  
Count the number of 1s in the mask

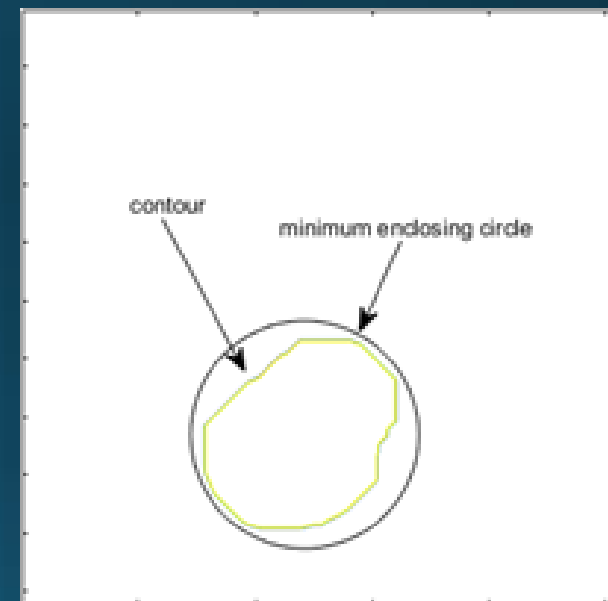

VERY GOOD RESULTS!!!

# CONTROL FLOW (SOFTWARE)

- There are 4 commands that will be executed by the robot
- Each command has a binary code that corresponds to the dedicated PWM channel on Atmega microcontroller
- Raspberry pi detects the balloons and sends a command to Atmega
- The command would activate the corresponding PWM channel

Direction	PWM1	PWM2	PWM3	PWM4	Binary Code
Forward	On	Off	On	Off	1010
Backward	Off	On	Off	On	0101
Left	On	Off	Off	On	1001
Right	Off	On	On	Off	0110

# CONTROL FLOWCHART

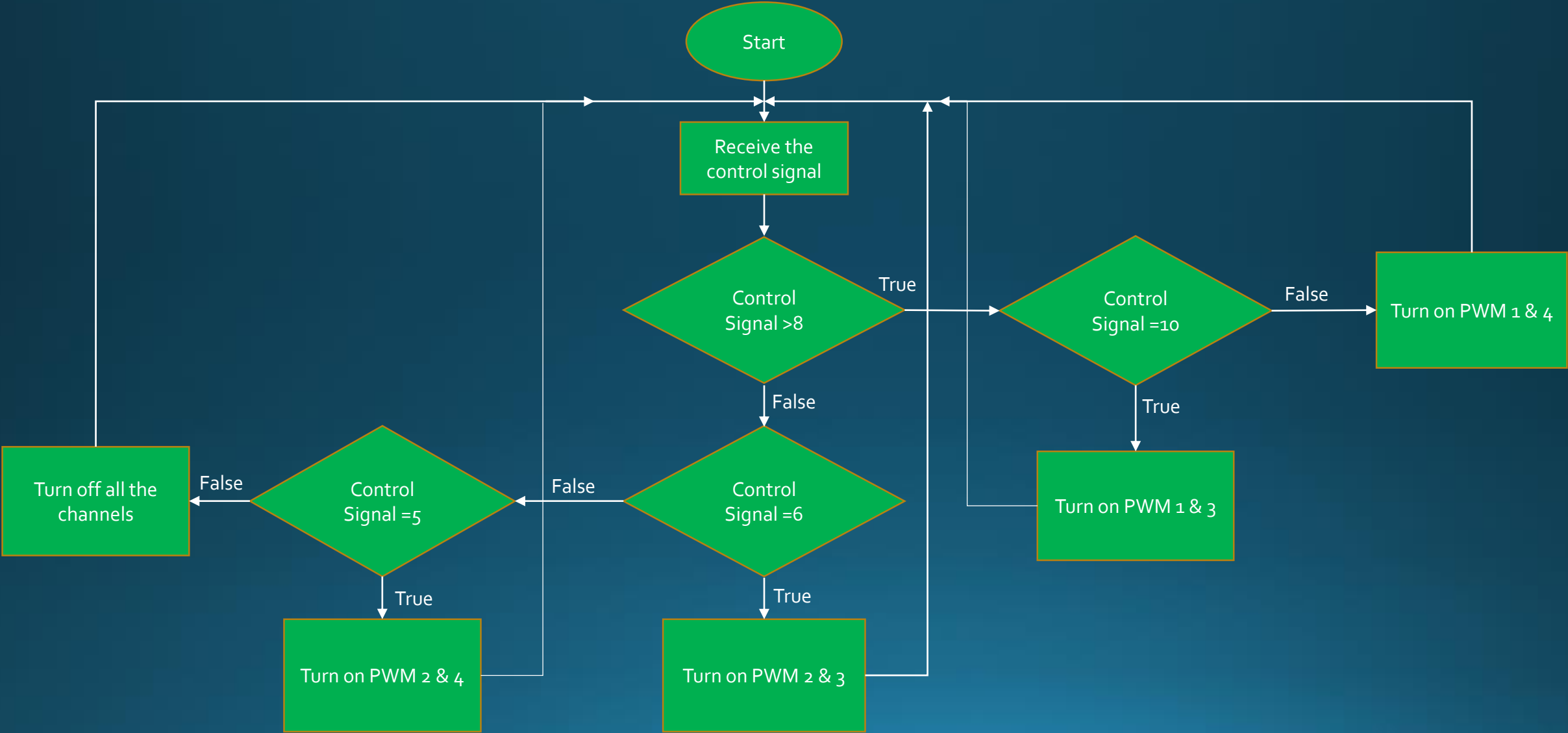

# MOTOR DRIVER

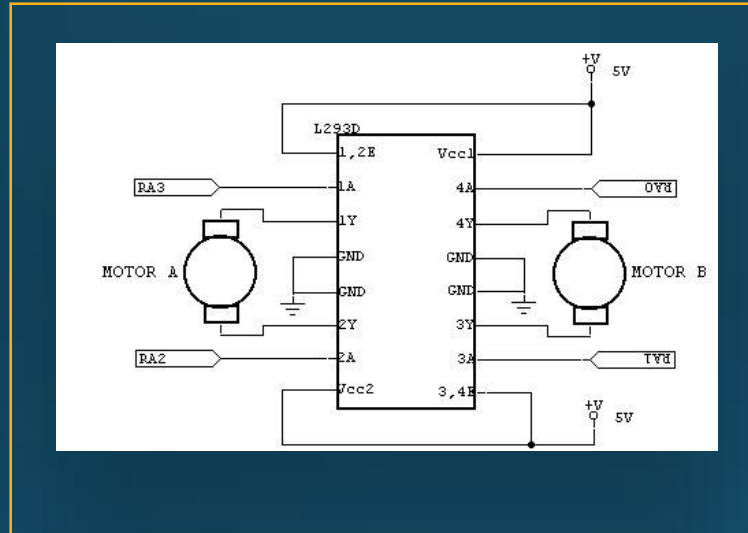

## L293D

- Supplied  $V = 4.5-36V$
- Separate Input-logic
- $I_{out} = 1.2A$
- Clamping Diodes
- \$1/driver

# PROJECT BUDGET

Component	Quantity	Cost (ea)	Total Cost
Raspberry Pi 3 Computer Board	1	\$39.95	\$39.95
BQ21040 BMS Integrated Circuit	5	\$1.34	\$6.70
MCU: ATMEGA328P	2	\$2.34	\$4.68
Buck Converter (3.3 volt)	5	\$0.58	\$2.90
Buck Converter (5 volt)	2	\$5.00	\$10.00
Fixed 5V/2A Linear Voltage Regulator	2	\$2.25	\$4.50
3.7/4.2 2500mah Lithium Polymer Batteries	2	\$7.99	\$15.98
PCB layout charge	15	\$6.00	\$45.00
RC Sumo Jump Vehicle	1	\$29.99	\$29.99
Raspberry Pi accessory kit	1	\$20.00	\$20.00
Passives	n/a	n/a	\$25.00
Wireless Keyboard/Mouse	1	\$30.00	\$30.00
HD Monitor	1	\$80.00	\$80.00
460mW/405nm laser	1	\$70.00	\$70.00
15mW/50mW laser	2	\$20.00	\$40.00
MOTOR DRIVER: L293D	10	\$1.00	\$10.00
Aluminum Alloy Tank Chassis	1	\$87.99	\$87.99
Total Cost	--	--	\$498.39

# CURRENT PROGRESS - DESIGN

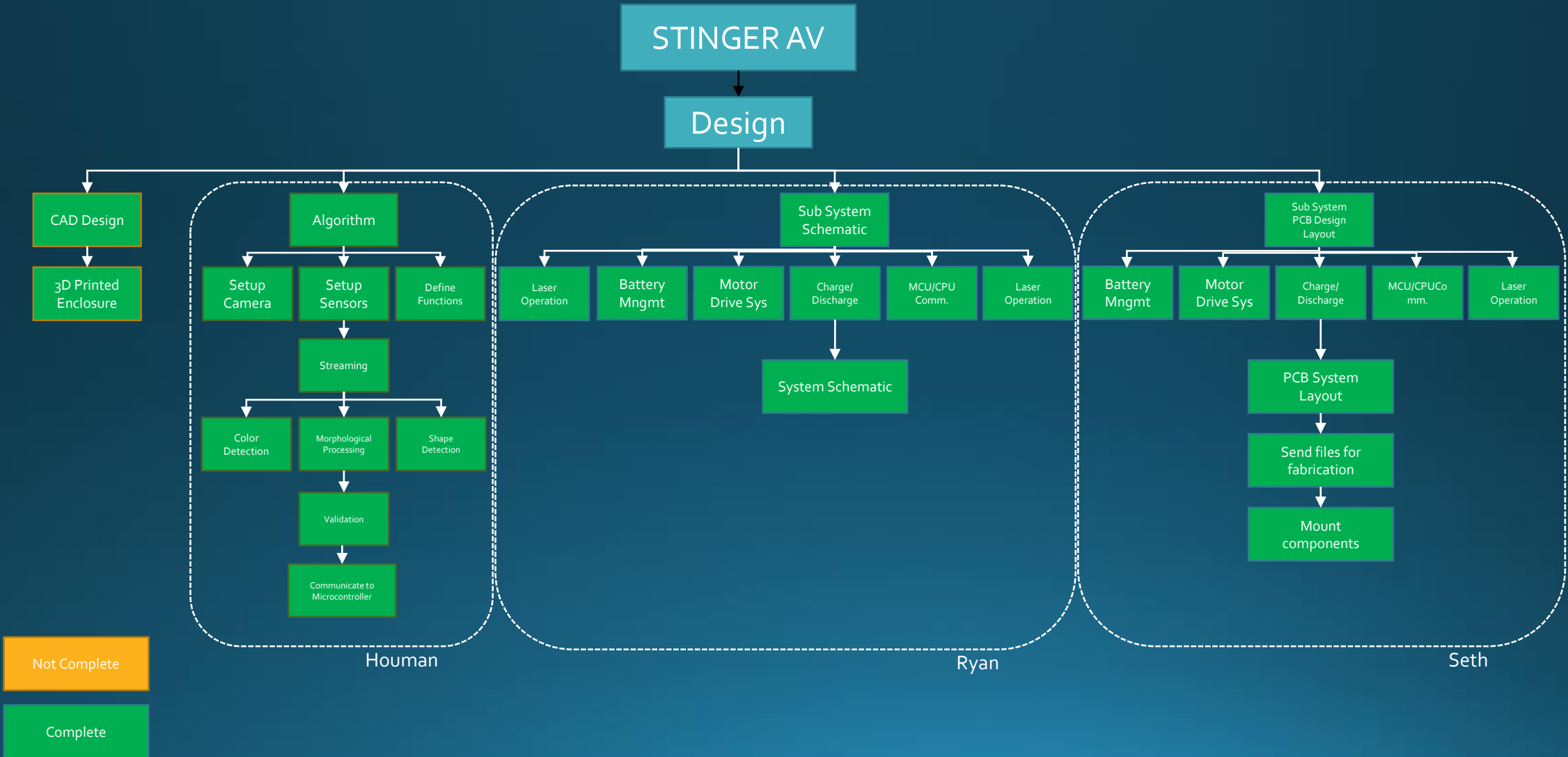

# CURRENT PROGRESS - PROTOTYPE

